

String Inverter (SUN2000-17/20KTL)



Smart

- 3 MPPTs for versatile adaptations to different module types or quantities built up with different alignments
- 6 strings intelligent monitoring and 80% time saving for fault detection
- RS485 and USB ports for connectivity and data management
- Local graphic LCD display and remote monitoring

Efficient

- Max. efficiency 98.6%, European efficiency 98.3%
- Easy to install with the weight of 48kg

Safe

- DC disconnect integrated, safe and convenient for maintenance
- Type II surge arresters for both DC and AC
- Ground fault protection
- Residual Current Detection (RCD) protection

Reliable

- No need for external fans with natural cooling technology
- Protection rating of IP65



Efficiency Curve

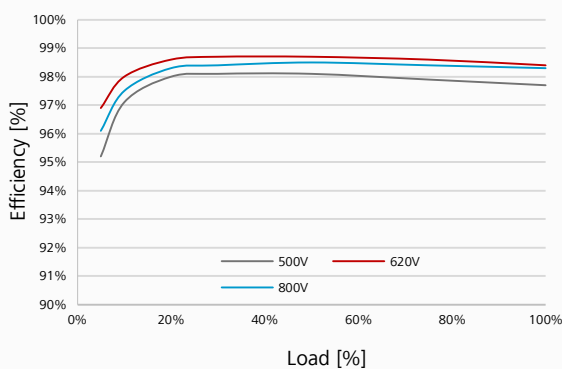

Circuit Diagram

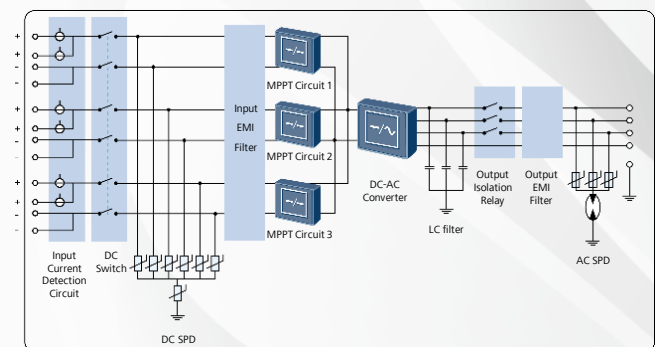

SUN2000-17/20KTL



String Inverter (SUN2000-17/20KTL)



Technical Specifications	SUN2000-17KTL	SUN2000-20KTL
Efficiency		
Max. Efficiency	98.6%	98.6%
European Efficiency	98.3%	98.3%
Input		
Max. DC Usable Power	19,100 W	22,500 W
Max. Input Voltage	1,000 V	1,000 V
Max. Current per MPPT	18 A	18 A
Max. Short Circuit Current per MPPT	25 A	25 A
Min. Operating Voltage / Start Input Voltage	200 V / 250 V	200 V / 250 V
Full Power MPPT Voltage Range	400 V ~ 800 V	480 V ~ 800 V
MPPT Operating Voltage Range	200 V ~ 950 V	200 V ~ 950 V
Rated Input Voltage	620 V	620 V
Max. Number of Inputs	6	6
Number of MPP Trackers	3	3
Output		
Rated AC Active Power	17,000 W	20,000 W
Max. AC Apparent Power	18,700 VA	22,000 VA
Max. AC Active Power (cosφ=1)	18,700 W	22,000 W
Rated Output Voltage	220V / 380V, 230V / 400V, 3W+N+PE	220V / 380V, 230V / 400V, 3W+N+PE
Rated AC Grid Frequency	50 Hz / 60 Hz	50 Hz / 60 Hz
Max. Output Current	28.4 A	33.4 A
Adjustable Power Factor	0.8 LG ... 0.8 LD	0.8 LG ... 0.8 LD
Max. Total Harmonic Distortion	< 3%	< 3%
Protection		
Input-side Disconnection Device	Yes	Yes
Anti-Islanding Protection	Yes	Yes
AC Overcurrent Protection	Yes	Yes
DC Overcurrent Protection	Fuseless	Fuseless
DC Reverse-Polarity Protection	Yes	Yes
PV-array String Fault Monitoring	Yes	Yes
DC Surge Arrester	Type II	Type II
AC Surge Arrester	Type II	Type II
Insulation Monitoring	Yes	Yes
Residual Current Detection	Yes	Yes
Communication		
Display	Graphic LCD	Graphic LCD
RS485	Yes	Yes
USB	Yes	Yes
General		
Dimensions (W×H×D)	520 x 610 x 255 mm (20.5 x 24.0 x 10.0 inch)	520 x 610 x 255 mm (20.5 x 24.0 x 10.0 inch)
Weight	48 kg (105 lb.)	48 kg (105 lb.)
Operation Temperature Range	-25 °C ~ 60 °C (-13°F ~ 140°F)	-25 °C ~ 60 °C (-13°F ~ 140°F)
Cooling	Natural Convection	Natural Convection
Operating Altitude	3,000 m (9,842 ft.)	3,000 m (9,842 ft.)
Relative Humidity	0~100%	0~100%
DC Connector	Amphenol H4	Amphenol H4
AC Connector	Amphenol C16/3	Amphenol C16/3
Protection Rating	IP65	IP65
Internal Consumption at Night	< 1 W	< 1 W
Topology	Transformerless	Transformerless
Noise Emission (Typical)	<29 dB	<29 dB
Standards Compliance		
Safety / EMC	EN/IEC 61000-6-1, EN/IEC 61000-6-2, EN/IEC 61000-6-3, EN/IEC 61000-6-4, EN/IEC 62109-1, EN/IEC 62109-2	
Grid Code	IEC 61727, IEC 62116, NB/T 32004-2013, VDE-AR-N-4105, VDE 0126-1-1, BDEW, G59/3, UTE C 15-712-1, CEI 0-16, CEI 0-21, C10/11, EN 50438-Ireland, EN 50438-Turkey, AS 4777, PEA (Only 20KTL), MEA (Only 20KTL), NRS 097-2-1	

Always Available for Highest Yields



www.huawei.com/solar